

E5XXXA SERIES

Cost-Saving, Versatile Monitoring Solution with Associated E683x Rope Style CTs (Sold Separately)



E50xxxA/E51xxxA



E683x Series Rope CT (sold separately)

The E5xxxA Series DIN Rail Meter combines exceptional metering performance with a built-in integrator and power supply to deliver a cost-effective, easily installed solution for power monitoring applications. Multiple communication protocol options offer added flexibility for easy system integration.

E5xxxA devices work exclusively with Veris E683x Series rope CTs for fast connection. The rope style CTs allow convenient installation in tight spaces.

The data logging capability (E5xC3A and E5x5A) protects data in the event of a power or communications failure elsewhere in the system. Different devices in the series offer serial communication, pulse output, and phase alarms to suit a wide variety of applications.

SPECIFICATIONS

ACCURACY	
Real Power & Energy E5xxxA	0.5% (ANSI C12.20, IEC 62053-22 Class 0.5S)
INPUTS	
Control Power, AC	50/60 Hz; 5 VA max.; 90 V min.; UL Maximums: 600 VL-L (347 VL-N); CE Maximum: 300 VL-N
Control Power, DC	3 W max.; UL and CE: 125 to 300 Vdc (external DC current limiting required)
Voltage Input	UL: 90 VL-N to 600 VL-L; CE: 90 VL-N to 300 VL-N
Current Input Scaling Input Range	50 to 5000 A E683x Series rope style CTs only (CTs must be rated for connection to Class 1 voltage inputs)
Pulse Inputs (E5xHxA & E50FxA only)	Contact inputs to pulse accumulators (one set with E5xH2A & E50F2A; two sets with E5xH5A & E51F5A)*
OUTPUTS	
All Models (except E5xHxA & E50FxA)	Real Energy Pulse: N.O. static**; Alarm contacts: N.C. static**
E50BxA	Reactive energy pulse**
E5xCxA	RS-485 2-wire Modbus RTU (1200 baud to 38.4 kbaud)

Faster installation 0.5% accuracy

Integrator and power supply for the CTs are built into the meter... fewer devices to purchase and faster installation

ANSI C12.20 0.5% accuracy, IEC 62053-22 Class 0.5S on all E5xxxA...great for cost allocation

Rope CTs

Versatile rope CTs allow convenient installation in tight spaces

Easy installation

DIN rail or screw mounting options

400 to 5000A

Designed to work exclusively with E683x Series rope CTs which offer 1% accuracy from 50 to 5000 A... monitor a wide range of loads with breakers from 400 to 5000 A

Multiple applications

Real energy output and phase loss alarm output on E50BxA and E5xCxA models...one device serves multiple applications

APPLICATIONS

- Energy monitoring in building automation systems
- Renewable energy
- Energy management
- Commercial sub-metering
- Industrial monitoring
- Cost allocation

E5xHxA	RS-485 2-wire BACnet MS/TP (9600 baud to 115.2 kbaud)
E50FxA	2-wire LON FT
MECHANICAL	
Mounting	DIN rail or 3-point screw mount
ENVIRONMENTAL	
Operating Temp Range	-30 to 70 °C (-22 to 158 °F)
Storage Temp Range	-40 to 85 °C (-40 to 185 °F)
Humidity Range	<95% RH non-condensing; indoor use only
WARRANTY	
Limited Warranty	5 years
AGENCY APPROVALS	
Agency Approvals	UL508, EN61010, California CSI Solar, ANSI C12.20



*10 kΩ Vac/dc to 4 to 10 Vdc.

**30 Vac/dc, 100 mA max.

***The CE mark indicates RoHS2 compliance. Please refer to the CE Declaration of Conformity for additional details.



ORDERING INFORMATION

	E50B1A	E50C2A	E50C3A	E50F2A	E50F5A	E50H2A	E50H5A	E51C2A	E51C3A	E51H2A	E51H5A
MEASUREMENT CAPABILITY - FULL DATA SET											
Bi-directional Energy Measurements											
Power (3-phase total and per phase): Real (kW) Reactive (kVAR), & Apparent (kVA)	•	•	•	•	•	•	•	•	•	•	•
Power Factor: 3-phase average & per phase	•	•	•	•	•	•	•	•	•	•	•
Present Power Demand: Real (kW), Reactive (kVAR), and Apparent (kVA)	•	•	•	•	•	•	•	•	•	•	•
Import & Export totals of Present Power Demand: Real (kW), Reactive (kVAR), & Apparent (kVA)								•	•	•	•
Peak Power Demand: Real (kW), Reactive (kVAR), and Apparent (kVA)	•	•	•	•	•	•	•	•	•	•	•
Current (3-phase average and per phase)	•	•	•	•	•	•	•	•	•	•	•
Voltage: Line-Line and Line-Neutral (3-phase average and per phase)	•	•	•	•	•	•	•	•	•	•	•
Frequency	•	•	•	•	•	•	•	•	•	•	•
ANSI C12.20 0.5% accuracy, IEC 62053-22 Class 0.5S	•	•	•	•	•	•	•	•	•	•	•
Accumulated Net Energy: Real (kWh), Reactive (kVARh), and Apparent (kVAh)	•	•	•	•	•	•	•	•	•	•	•
Accumulated Real Energy by phase (kWh)	•	•	•	•	•	•	•	•	•	•	•
Import and Export Accumulators of Real and Apparent Energy								•	•	•	•
Reactive Energy Accumulators by Quadrant (3-phase total and per phase)								•	•	•	•
Demand Interval Configuration: Fixed or Rolling Block	•	•	•	•	•	•	•	•	•	•	•
Demand Interval Configuration: External Sync to Comms	•	•	•	•	•	•	•	•	•	•	•
DATA LOGGING											
Data Logging: 10 16-Bit Configurable (can include Date/Time) Data Buffers			•						•		
Data Logging: 3 Timestamped 32-Bit Configurable Data Buffers					•		•				•
Store up to 60 days of readings at 15-minute intervals			•		•		•		•		•
OUTPUTS											
Alarm Output (N.C.)	•	•	•	•		•		•	•	•	
1 Pulse Output (N.O.)		•	•					•	•		
2 Pulse Outputs (N.O.)	•										
RS-485 Serial (Modbus RTU Protocol)		•	•					•	•		
RS-485 Serial (BACnet MS/TP Protocol)						•	•			•	•
LONFT Serial (LonTalk Protocol)				•	•						
INPUTS											
2 Pulse Contact Accumulator Inputs				•		•					•
1 Pulse Contact Accumulator Input				•		•				•	

REQUIRED CTS

MODEL	DESCRIPTION
E683C502	Rogowski CT, 250 mm (9"), 600 V, 5 kA, U018 equivalent
E683D502	Rogowski CT, 300 mm (12"), 600 V, 5 kA, U018 equivalent
E683G502	Rogowski CT, 460 mm (18"), 600 V, 5 kA, U018 equivalent
E683J502	Rogowski CT, 600 mm (24"), 600 V, 5 kA, U018 equivalent
E683L502	Rogowski CT, 900 mm (35"), 600 V, 5 kA, U018 equivalent

DIMENSIONAL DRAWING

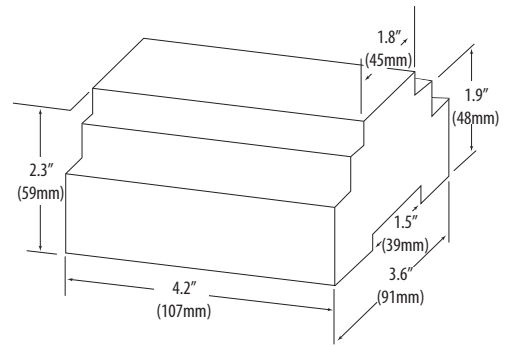

DIN MOUNT CONFIGURATION

Mounting Diagram

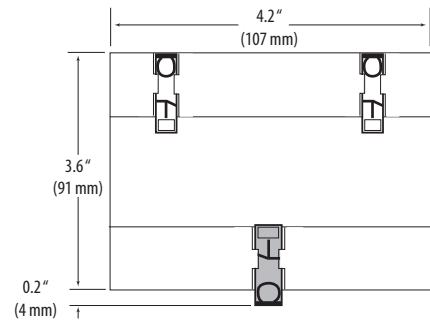

SCREW MOUNT CONFIGURATION

Mounting Diagram

